



Type 1 bonded button-fix

The Button-fix concept is simple: durable polymer Fixes are attached to the back of one panel and the mating Buttons are attached to the other.

Bring the panels together and slide until the Button-fixes 'click'.

The Type 1 Bonded Fix is for applications where screw-fixing to the panel is not possible and bonding is the preferred option.

It can be configured in different ways to best suit your application, either surface-mounted or rebated into the panel, and orientated for vertical or sideways assembly.

MANUFACTURED IN THE UK

Buttonfix Limited retains the right to modify the instructions as it deems appropriate and the consumer is responsible for checking the website for the latest information.

WARNINGS

—Button-fix is intended for furniture construction and interior fittings and is not intended, nor should it be used, for any other purpose.

—**WARNING:** Serious damage to property and severe bodily injury can result from (1) improper use, application or installation of the Button-fix or (2) use as part of improperly designed or constructed assemblies or materials.

—**WARNING:** Use of adhesives other than the self-adhesive Fix-pads, 2-part structural acrylic adhesive, or solvent weld for bonding to acrylic, may not be effective for proper bonding of the Fix. Buttonfix disclaims any and all liability for use of adhesives other than the Fix-pads.

—Always follow the adhesive manufacturer's recommendations on substrate suitability, preparation and loadings, and perform your own tests as necessary.

—**CAUTION:** Please remember that many factors can affect the use and performance of the Fix-pads in a particular application. The materials to be bonded to the product, the conditions in which the product is used, and the time and environmental conditions in which the product is expected to perform are among the many factors that can affect the use and performance of the Fix-pads, some of which are uniquely within the consumer's knowledge and control. It is essential that the consumer evaluates the Fix-pad to determine whether it is fit for a particular purpose and suitable for the consumer's methods of application.

—When using the self-adhesive Fix-pads, we strongly advise that the Fixes are used in the rebated configuration. If Fix-pads are used in the surface-mounted configuration, the loading should be limited to a maximum of 2kg (4.4lbs) per Fix.

—Avoid any contact with aggressive solvents and cleaning products.

—It is not possible for Buttonfix to warn the consumer about every possible danger related to use of the Button-fix and the consumer must use his or her own good judgment when installing and using the Button-fix.

THE BUTTON

There are two Buttons to suit different screw types. These are colour-coded lime green for $\varnothing 5\text{mm}$ countersunk wood screws, or orange for $\varnothing 6.2\text{mm}$ Varianta Euro screws (to fit $\varnothing 5\text{mm}$ pilot holes).

Check with your material supplier which screw type is best for your application.

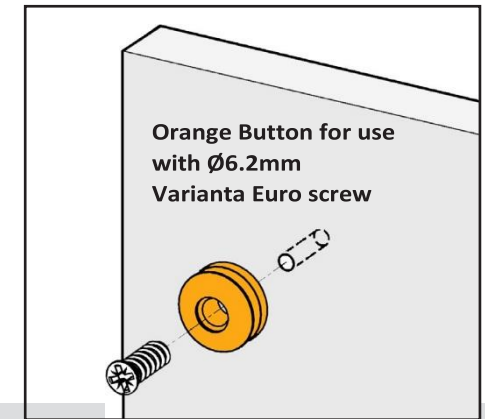
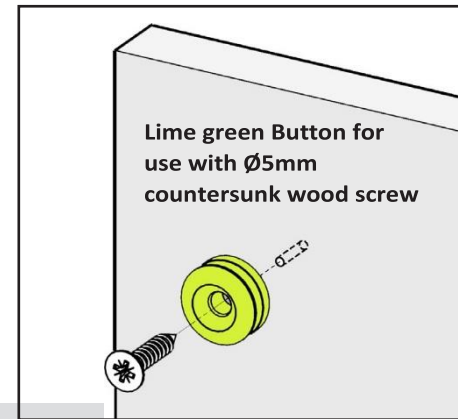

SUGGESTED LAYOUT

As an approximate guide, we suggest that Button-fix centres are no greater than 600mm apart and no closer than 35mm to the edge of the panel.

Always remember to allow at least 15mm clearance for the removable panel to disengage.

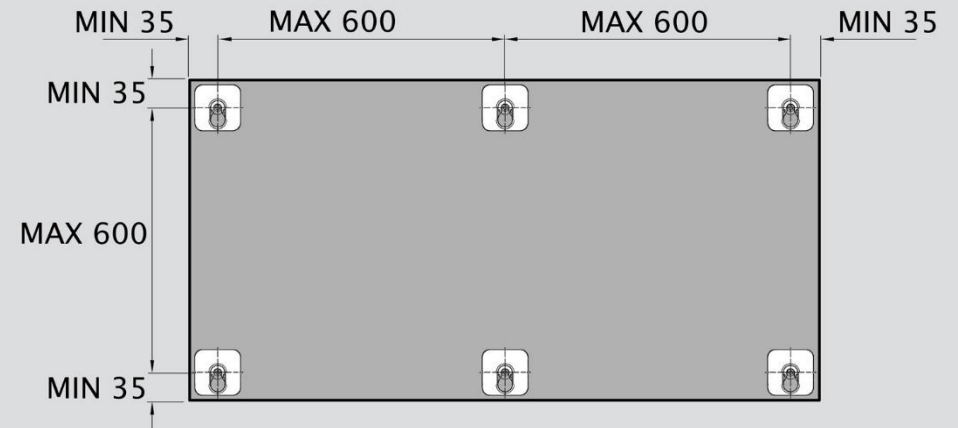

BUTTON MARKER ACCESSORY

The Button marker accessory helps to mark out where to install the Buttons.

Once the Fix mouldings are bonded (see following pages), snap a marker into each one. Then position the panel and press firmly. The markers will leave indents in the mounting surface, which can be used as guides for drilling pilot holes for the Buttons.

Remove the markers, which can be re-used to mark out the next panel.

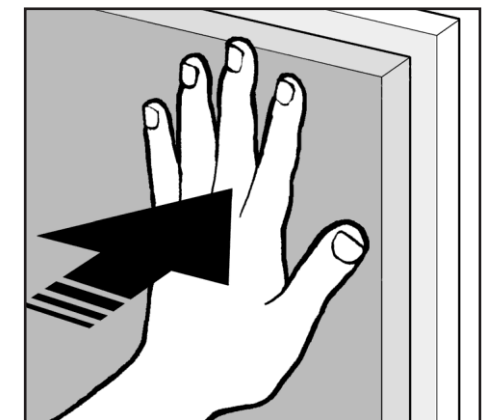

SURFACE-MOUNTED FIX

For applications where it is not possible to machine the panel material, the Fix can be surface-mounted. This creates an 8mm gap between the panel and the mounting surface.

Care must be taken to ensure the Fixes are correctly bonded to the panel.

It is imperative that all the Fixes on a panel are aligned with each other. Use a square to check alignment.

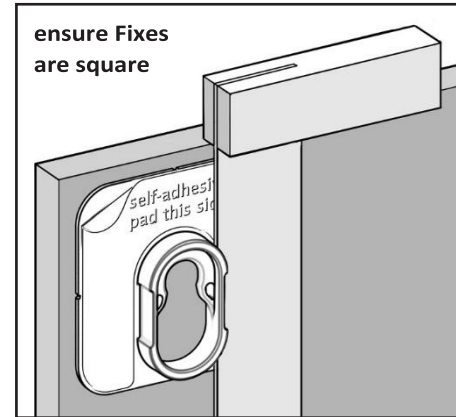
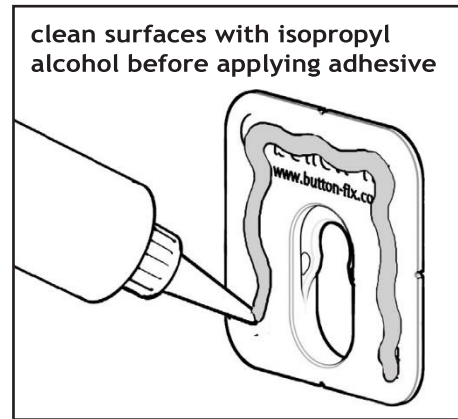

SUITABLE ADHESIVES

The Fix is manufactured in ABS plastic. There are many structural adhesives suitable for bonding it to a wide range of panel materials, e.g. a 2-part structural acrylic adhesive, a matched adhesive for solid surface (Corian®, Hanex®, etc.) or solvent weld for bonding to acrylic. Always follow the adhesive manufacturer's recommendations on substrate suitability, preparation and loadings.

VERTICAL ARRANGEMENT

The Fix may be bonded to the removable panel in a vertical orientation, as shown in the diagram on the right.

In this configuration, the panels engage vertically and 15mm clearance is required above the removable panel.

Note: the Fix should be inverted if it is bonded to the mounting surface.

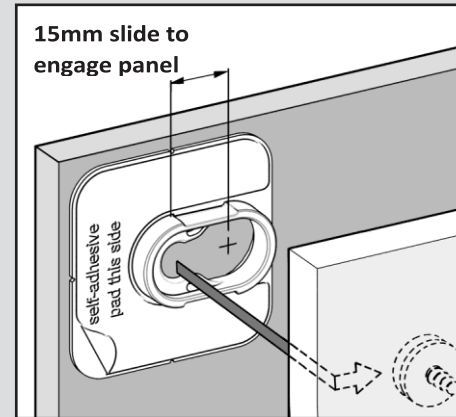
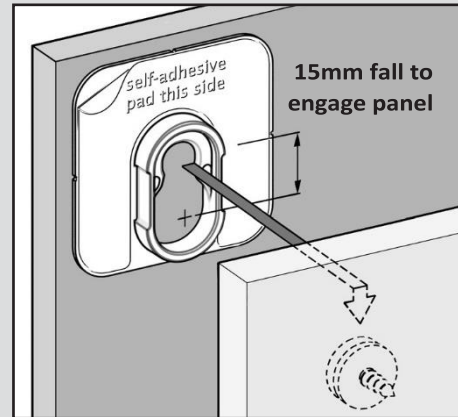

SIDEWAYS ARRANGEMENT

The Fix may be bonded to either the removable panel or the mounting surface in a sideways orientation, as shown in the diagram on the left.

In this configuration, the panels engage horizontally and 15mm clearance is required to the side of the removable panel.

USEFUL TIPS

When marking out the position of the Fixes on the panel, use the guide marks at the edge of the moulding to align with centre lines.

The centre line guide also corresponds with the position of the Button on the mating panel.

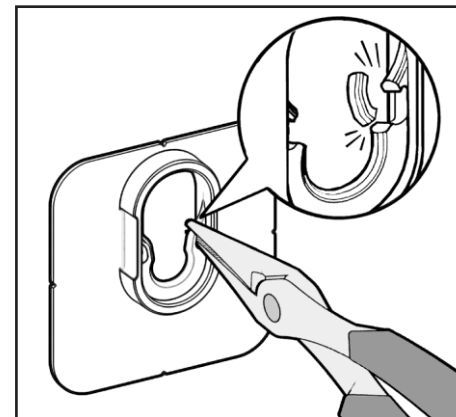
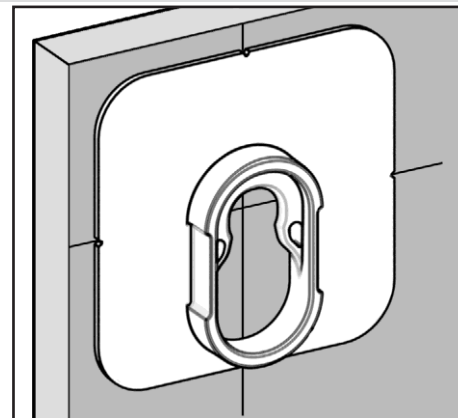

When several Button-fixes are used on a panel or if you require the panel to be easily removable, you can reduce the strength of the click-fit.

To achieve this adapt some (but not all) the Fix mouldings by snapping off the ears with needle-nosed pliers, as shown in the diagram on the left.

REBATEDFIX

For applications where it is possible to machine a 7mm deep rebate in the panel, a stronger panel support can be achieved as the rebate supports the Fix in shear. The rebate also helps to align the Fix while bonding.

Rebating the Fix creates a nominal 2mm gap between the two panels.

Read the notes on the previous page regarding suitable adhesives and surface preparation.

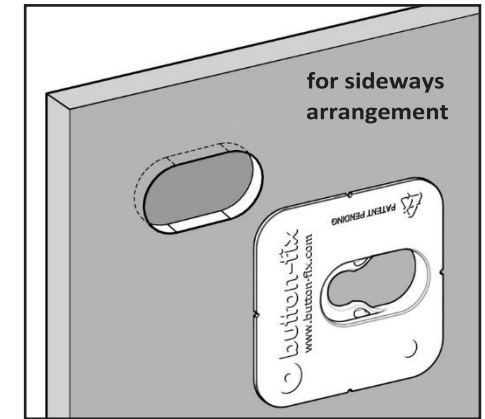
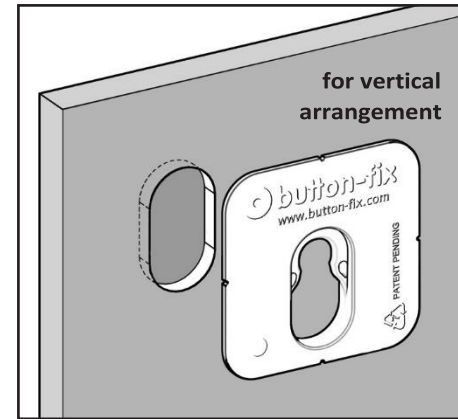
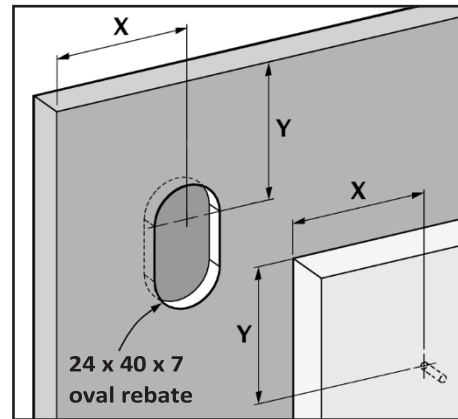

VERTICAL ARRANGEMENT

The Fix may be bonded to the removable panel in a vertical orientation, as shown in the diagram on the right.

In this configuration, the panels engage vertically and 15mm clearance is required above the removable panel.

Note: the Fix should be inverted if it is bonded to the mounting surface.

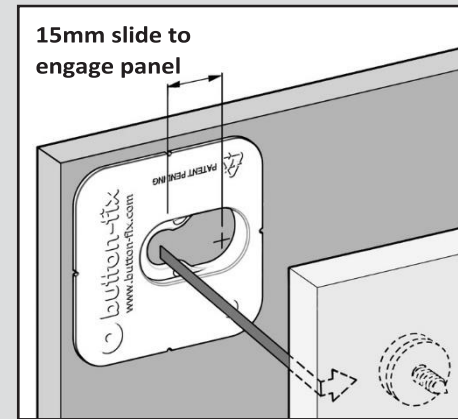
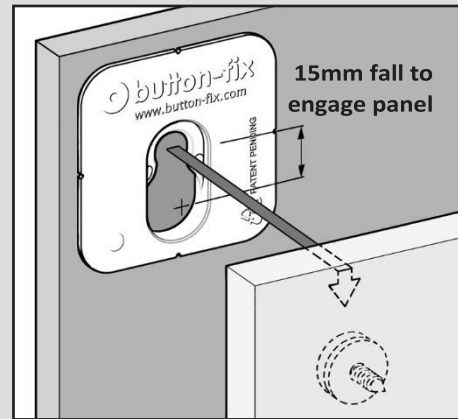

SIDEWAYS ARRANGEMENT

The Fix may be bonded to either the removable panel or the mounting surface in a sideways orientation, as shown in the diagram on the left.

In this configuration, the panels engage horizontally and 15mm clearance is required to the side of the removable panel.

SELF-ADHESIVE FIX-PADS

The Fix may also be bonded using self-adhesive Fix-pads (ordered separately).

We strongly advise that the self-adhesive Fix-pads are used in the rebated configuration, shown on this page, to avoid possible creep under loading.

If Fix-pads are used in the surface-mounted configuration, the loading should be limited to a maximum of 2kg per Fix.

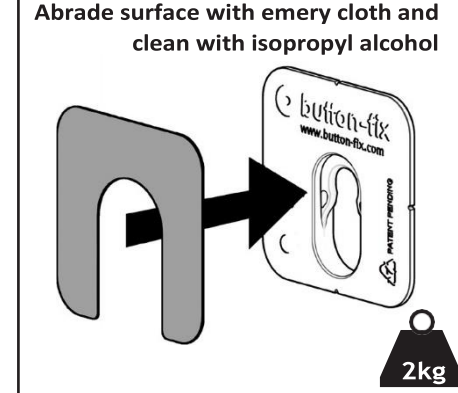
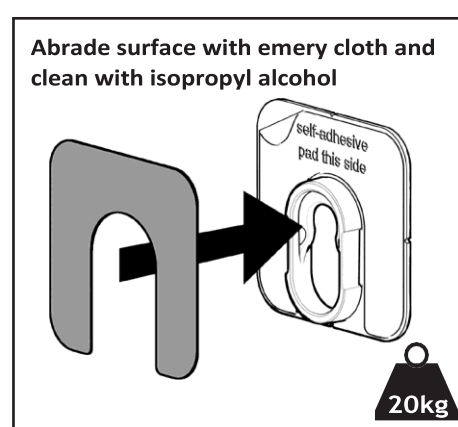

For best results when using Fix-pads, the surface of the Fix should be abraded using emery paper (180 grit) and both surfaces must be cleaned with isopropyl alcohol.

We highly recommend that the assembled Fixes be clamped to ensure good contact, and should not be fully loaded for at least 24 hours. At room temperature approximately 50% of ultimate bond strength will be achieved after 20 minutes, 90% after 24 hours and 100% after 72 hours.

ROUTER JIG ACCESSORY

A router jig can be ordered separately for accurately machining the rebates for the Fixes, described on the previous page.

The jig is designed for use with a metric 12mm cutter and 18mm guide bush. Read the separate instructions supplied with the accessory before use.

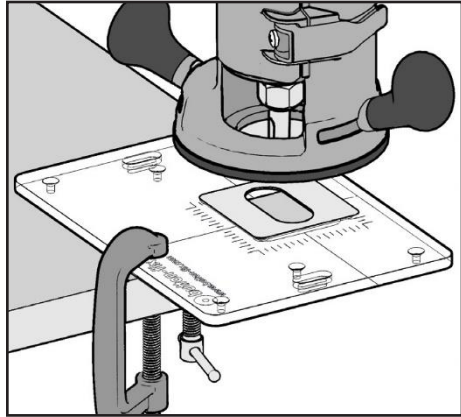

BUTTON DIMENSIONS

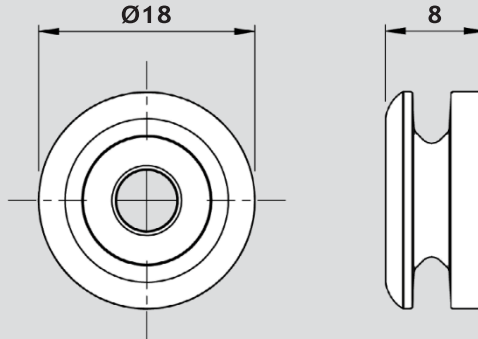

TYPE 1 BONDED FIX DIMENSIONS

